

**FOR A CENTURY, PRIDE OF THE FARM HAS
DELIVERED WATER IN RELIABLE, RUGGED DRINKERS**

**TODAY WE HAVE OVER 30 OPTIONS TO DO IT
NO ENERGY COST.....OR.....LOW ENERGY COST**

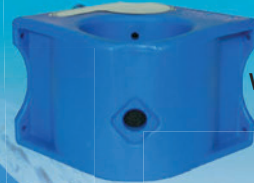

MBH5B



WPO1BE



WPM14A



WPO12E



WPM10



WPO25E



WPM20

**FOR YOU. FOR YOUR FARM.
FOR A CENTURY.**



WPM120



WPO50N

WPO70N

Industry's Best Warranty!

- All Poly Main Components
5 Years Unconditional Warranty
- And An Additional 11 Year
Pro-Rated Warranty
- Valve & Heater - 18 Month
Unconditional Warranty

Six generations have known, if you want to buy it once.....buy Pride of the Farm®



Pride of the Farm®
watered field hands
in 1923!



In 1979, Pride of the Farm became the
first animal drinker manufacturer to use
polyurethane foam insulation.



Our first Polar-Max® 100%
Energy Free Drinker was
introduced in 1988.



In 1999, Pride of the Farm®
introduced Performance One
E-Drinkers, our series of energy
efficient, electrically heated drinkers.

WHY PRIDE OF THE FARM?.....TEN REASONS

1. Our valves and flow rates, our designs, our quality are all directed toward job number one-WATER. Delivered efficiently and hassle free.

2. On most models, we double protect the valve. FOUR sided insulated baffle walls plus the drinker base wall.

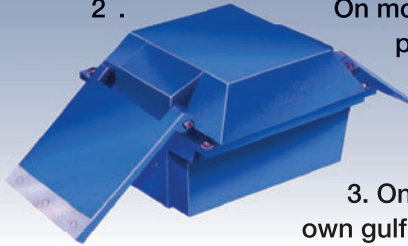

3. On heated models we set our own gulf stream into motion with patented water circulation holes in the valve cover.

4. Grade A dairy compliant.

5. Service. We work with you on unusual applications. We help you solve your problems.

6. We establish standards for foam voids and test against those



standards to give the best freeze protection.

7. We use the best stabilizers for UV protection-both for mechanical properties and for color fastness.

8. Either LOW cost or NO cost. With our heated drinkers, ANNUAL costs will be in the \$10 to \$25 range.

Compared with concrete drinkers, our electrical costs are a fraction.

9. Attention to detail. Example: molded in brass inserts – no fasteners directly into the plastic.

10. Longevity.



One of our largest distributors said this, "The top challenge I have selling Pride of the Farm is that your customers know your drinkers will last 30 years or more. They say – why buy a new drinker when the ones they have are probably good to go for another 30."

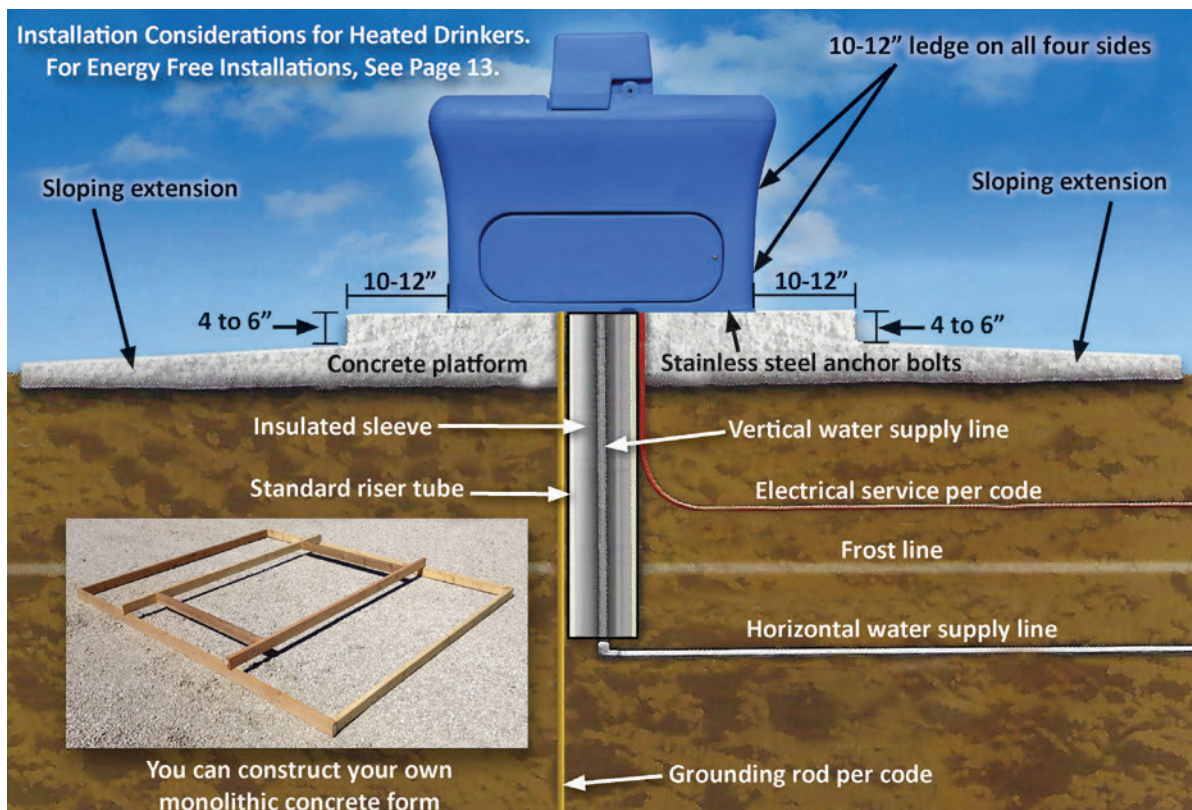

CLEAN WATER DELIVERED AT HIGH FLOW RATES

PRIDE OF THE FARMS 100% ENERGY FREE DRINKER- A BETTER ANSWER THAN CONTINUOUS FLOW

In irrigated areas, up to 30% of all agricultural water is used for cattle production with most being consumed in feed lots. Regardless of what happens with rainfall, the pressure will only increase to conserve water. Watershed management will continue to be prominent with well depth reporting, allocations and other regulatory actions on the rise. Pride of the Farm has the answer - MODEL WPM120 100% ENERGY FREE DRINKER. Our drinker will keep your animals watered using the least amount of water of any other option.

TAKE CONTROL BY CONSERVING WATER. DON'T LET THE REGULATORS FORCE YOU TO DO WHAT . . . YOU DON'T WANT TO DO !

Energy free drinkers are just that - zero energy costs incurred to provide ice free operations in cold weather months.

Because of our superior insulation, water stays cooler in the warmest months.

When was the last time you saw a headline which says:

"ELECTRIC RATES SET TO DECREASE"?

*We've Been Watering
Animals Since 1903!*



**POLAR-MAX® 100%
ENERGY FREE**

MODEL WPM120 is a proven performer in the demanding commercial feedyard applications



Our drinkers are so well insulated that some producers do not use flaps or remove some flaps even in winter (must have sufficient drinking activity)



MADE IN RURAL AMERICA!



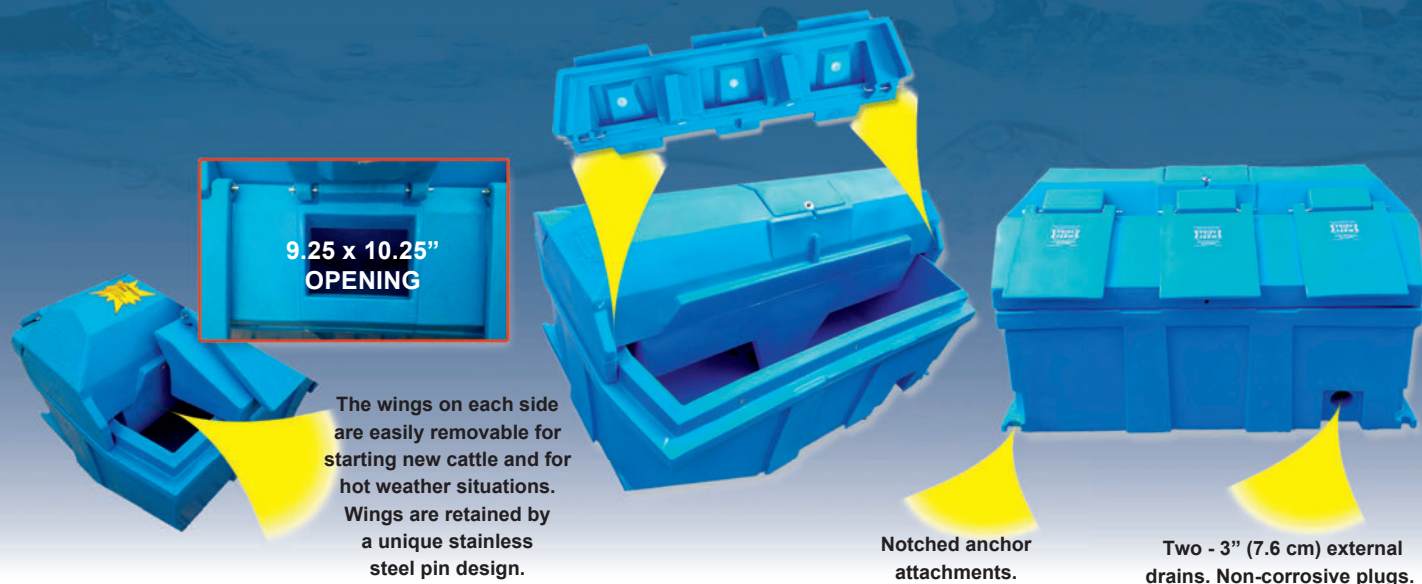

Model WPM120 is designed with an optional 3" (7.6 cm) internal drain which permits easy and fast cleaning and which also permits continuous flow operation. Drinker will drain in about 2 minutes.

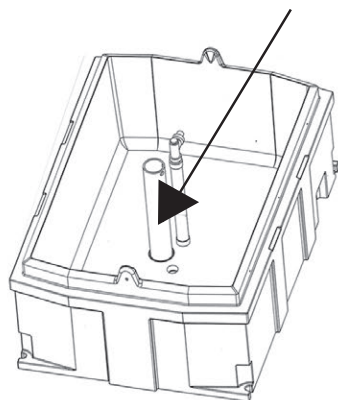

WPM120 FOOTPRINT TOP DOWN VIEW

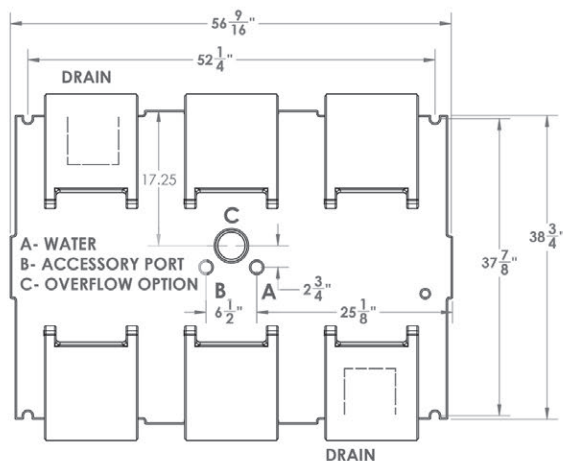

Top port is removable using no tools. When port is removed, you have top access to the valve, optional shutoff and our optional 3" (7.6 cm) internal drain.

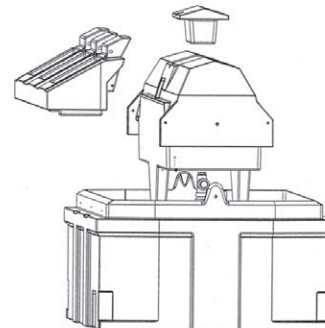

Specifications

MODEL NUMBER	APPROXIMATE CAPACITY			SIZE INCHES (CM)					WEIGHT LBS (KG)
	ANIMALS	WATER		DRINK OPENING	DRINK HEIGHT	OVERALL WIDTH**	OVERALL LENGTH	OVERALL HEIGHT	
		GALLONS	LITERS						
WPM120 A 6 opening drinker designed for commercial feedyards and dairies	350 Beef 150 Dairy 225 cow-calf	110	416.4	9.3 x 10.3 (23.5 x 26.0)	22.5 (57.2)	44 (111.8)	56.5 (144)	32.3 (82.0)	197 (89.5)
WPM120-O (WPM120 LESS WINGS)	350 Beef 150 Dairy 225 cow-calf	110	416.4	8.75 x 47.0 (22.2 x 119.4)	21.0 (53.3)	38 (96.5)	56.5 (144)	32.3 (82.0)	143 (65.0)

* Capacities may vary according to weather conditions, pen size and animal size. If in doubt, get a recommendation from your extension agent or other qualified individual.
 ** Overall width includes flap overhang

OUR CURRENT ENERGY FREE DESIGN HAS BEEN SUCCESSFULLY USED SINCE 1952!

USA patent numbers 321,769;322,336: 322,869: 3,877,482: 4,100,885: 4,542,715: 4,708,091: 4,962,730 and 5,105,711 and RE 34,427. Canadian patent number 2,017,662. NOTE: We've been at the energy-free waterer business longer than any other manufacturer. The Eaton division of Hawkeye Steel Products, Inc., owned the three oldest U.S. energy-free patents. These are patent numbers 1028998, issued June 11, 1912: 1,220,404, issued March 27, 1917: and 1,375,039, issued April 19, 1921.



WPO70 OPEN TROUGH TANK

MORE FEATURES • MORE DRINKING LENGTH • MORE GALLONS

Pride of the Farm's trough drinker is a favorite for feedyards, pastures and dairies. It has 70 inches of drinking length and holds 70 gallons. It is loaded with features not available on any competing trough drinker — extra supply line protection, patented water circulation, multiple constant flow and drain options. Grade A compliant.

Water circulation is assisted with our patented baffle design and discharge ports. Warmer water pushes through the ports. Colder water falls to the bottom and returns under the baffle.

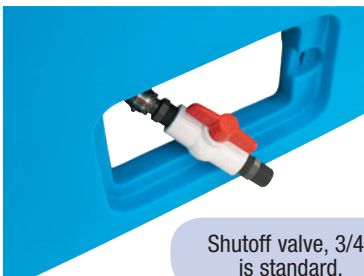
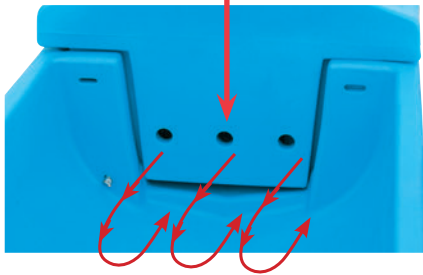

Shutoff valve, 3/4" is standard.

WPO70 FOOT-PRINT TOP DOWN VIEW

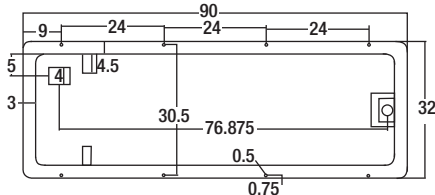

Specifications

MODEL NUMBER	APPROXIMATE CAPACITY			SIZE INCHES (cm)				HEATER ELECTRIC	SHIPPING WEIGHT Lbs. (kg)
	ANIMALS	WATER		DRINK HEIGHT	OVERALL WIDTH	OVERALL LENGTH	OVERALL HEIGHT		
		GALLONS	LITERS						
WPO70E	300 BEEF 150 DAIRY	70	265	26 (66)	32 (81.3)	90 (228.6)	34 (86.4)	500 watts	154 (69.9)
WPO70N	300 BEEF 150 DAIRY	70	265	26 (66)	32 (81.3)	90 (228.6)	34 (86.4)	none	152 (68.9)
NR100	Neck Rail. Hot dip galvanized steel. You need to install a neck rail with our drinker. See instructions & warranty.								

USA Patent Number 6,722,313 B2

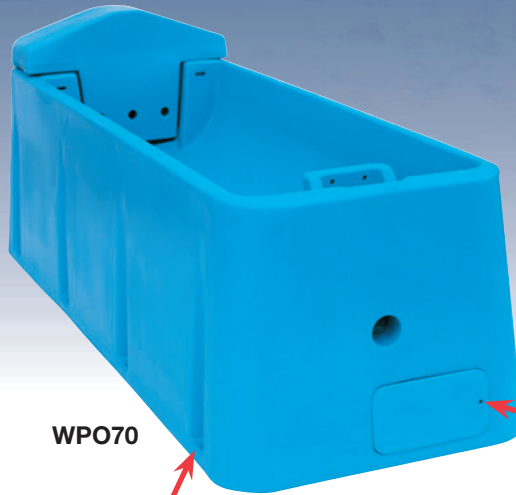

WPO70

Spring loaded pin allows access panel to pop off with the twist of a screwdriver. There are no loose parts.

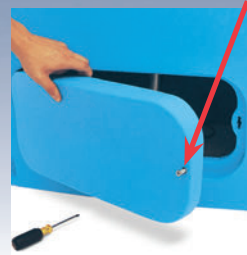

Lower access panels on each end. Each opening is 5" x 9".

Recessed, protected notches for anchoring. Our 8 notches do not protrude where they can be hit. Concrete stud lags included.

Superb supply line protection. Water supply line enters through our unique tower. The tower is foamed filled and the surrounding wall and valve cover are foam filled.

High flow valve.

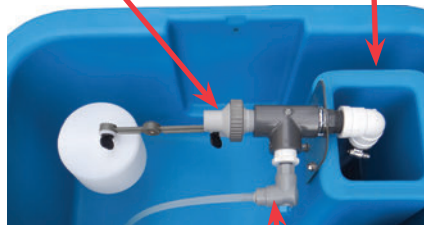

Continuous flow weep valve standard.

Trough slopes to drain.



HOW LOW CAN YOU GO?

Water level is easily adjustable. We give you just about all the range you will ever need.

Constant flow at 70 gallons here.

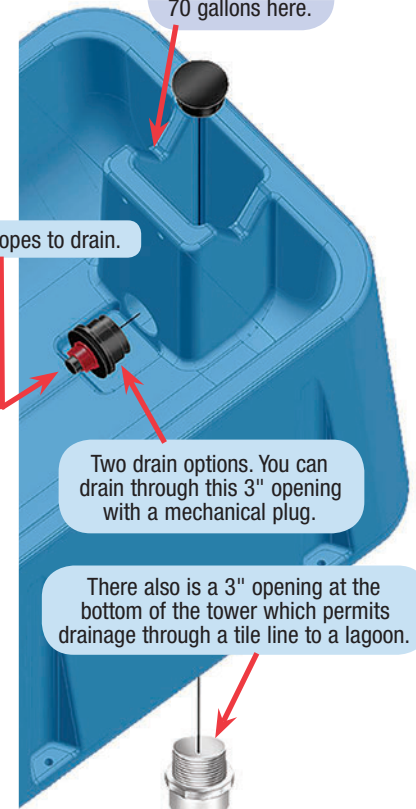

Two drain options. You can drain through this 3" opening with a mechanical plug.

There also is a 3" opening at the bottom of the tower which permits drainage through a tile line to a lagoon.



WPO50 OPEN TROUGH TANK

THESE ARE SHOWN ON PAGE 19

- Valve Cover with Water Circulation Ports
- Shut Off Valve
- Access Doors
- Valve
(The continuous flow weep valve is standard on WPO70 but it is an option on WPO50)



WPO50

3" Drain Plug. Drinker Drains Onto the Ground.

1 1/2" Port for Optional Overflow Kit

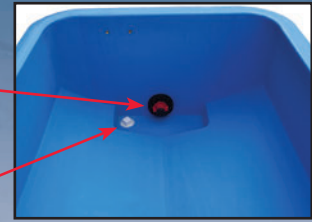

WPO50 FOOT-PRINT TOP DOWN VIEW

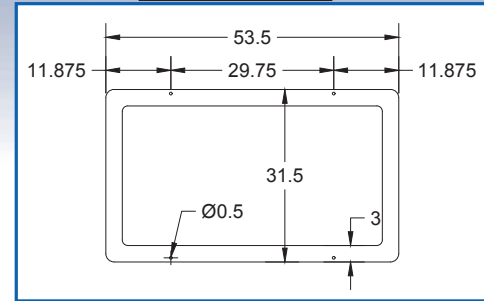

Industry's Best Warranty!

- All Poly Main Components
5 Years Unconditional Warranty
- And An Additional 11 Year
Pro-Rated Warranty
- Valve & Heater - 18 Month
Unconditional Warranty

Specifications

MODEL NUMBER	APPROXIMATE CAPACITY			SIZE INCHES (cm)				HEATER ELECTRIC	SHIPPING WEIGHT Lbs. (kg)
	ANIMALS	WATER		DRINK HEIGHT	OVERALL WIDTH	OVERALL LENGTH*	OVERALL HEIGHT		
		GALLONS	LITERS						
WPO50E	200 BEEF 100 DAIRY	50	189	24 1/2 (62.2)	31 (78.7)	54 (137.2)	32 1/4 (81.9)	500 watts	127 (57.7)
WPO50N	200 BEEF 100 DAIRY	50	189	24 1/2 (62.2)	31 (78.7)	54 (137.2)	32 1/4 (81.9)	none	125 (56.8)

Both Models WPO50 and WPO70 must have a neck rail installed over the trough. No neck rail in place will void the warranty. Do not let animals step in trough.

USA Patent Number 6,722,313 B2

*Drinking length is 34".



WPO50

WPO70



FOR YOU. FOR YOUR FARM.
FOR A CENTURY.